

# USER'S MANUAL BM039F BM038F

## Fork-clamp Multimeter Series



## 1) SAFETY

The meter meets IEC/EN/CSA\_C22.2\_No./UL standards of 61010-1 Ed. 3.0, 61010-2-032 Ed. 3.0, 61010-2-033 Ed. 1.0 to Measurement Categories CAT III 600V and CAT IV 300V ac & dc.

The accompanied test probe assembly meets IEC/EN/CSA\_C22.2\_No./UL standards of 61010-031 Ed. 2.0 to the same meter ratings or better. The 61010-031 requires exposed conductive test probe tips to be  $\leq 4\text{mm}$  for CAT III & CAT IV ratings. Refer to the category markings on your probe assemblies as well as on the add-on accessories (like detachable Caps or Alligator Clips), if any, for applicable rating changes.

### TERMS IN THIS MANUAL

**WARNING** identifies conditions and actions that could result in serious injury or even death to the user.

**CAUTION** identifies conditions and actions that could cause damage or malfunction in the instrument.

### WARNING











This manual contains information and warnings that must be followed for operating the meter safely and maintaining the meter in a safe operating condition. If the meter is used in a manner not specified by the manufacturer, the protection provided by the meter may be impaired.

Observe proper safety precautions when working with voltages above 30 Vrms, 42.4 Vpeak or 60 VDC. These voltage levels pose a potential shock hazard to the user. Do not expose this product to rain or moisture. The meter is intended only for indoor use.

Keep your hands/fingers behind the hand/finger barriers (of the meter and the test probe assembly, where applicable) that indicate the limits of safe access of the hand-held parts during measurements. Inspect lead wires, connectors, and probes for damaged insulation or exposed metal periodically. If any defects are found, replace them immediately. Only use the test probe assembly provided with the meter or a UL Listed test probe assembly to the same meter ratings or better.

Optional offer premium test probe assembly using silicone lead wire insulation, at agent's discretion, is equipped with white inner insulation layers as wear indicators. Replace them immediately if any of the white layers has become visible.

## INTERNATIONAL SYMBOLS

	Marking of Electrical and Electronic Equipment (EEE). Do not dispose of this product as unsorted municipal waste. Contact a qualified recycler
	Caution! Refer to the explanation in this Manual
	Caution! Possibility of electric shock
	Earth (Ground)
	Meter protected throughout by Double Insulation or Reinforced insulation
	Fuse
	Direct Current (DC)
	Alternating Current (AC)
	Three-phase Alternating Current
	Application around and removal from hazardous live conductors is permitted

## BRIEF INFORMATION ON MEASUREMENT CATEGORIES

**Measurement Category IV** is applicable to test and measuring circuits connected at the source of the building's low-voltage MAINS installation. Examples are measurements on devices installed before the main fuse or circuit breaker in the building installation.

**Measurement Category III** is applicable to test and measuring circuits connected to the distribution part of the building's low-voltage MAINS installation. Examples are measurements on distribution boards (including secondary meters), circuit-breakers, cables, bus-bars, junction boxes, switches, socket-outlets, stationary motors in the fixed installation, and equipment for industrial use.

**Measurement Category II** is applicable to test and measuring circuits connected directly to utilization points (socket outlets and similar points) of the low-voltage MAINS installation. Examples are measurements on MAINS CIRCUITS of household appliances, portable tools and similar equipment.

## 2) EUROPEAN DIRECTIVES

The instruments conform to EUROPEAN Low-Voltage Directive 2014/35/EU, Electromagnetic Compatibility Directive 2014/30/EU and RoHS 2 Directive 2011/65/EU plus amendment Directive (EU) 2015/863.

## 3) PRODUCT DESCRIPTION

This user's manual uses only representative model(s) for illustrations. Please refer detailed specifications for function availability to each model.

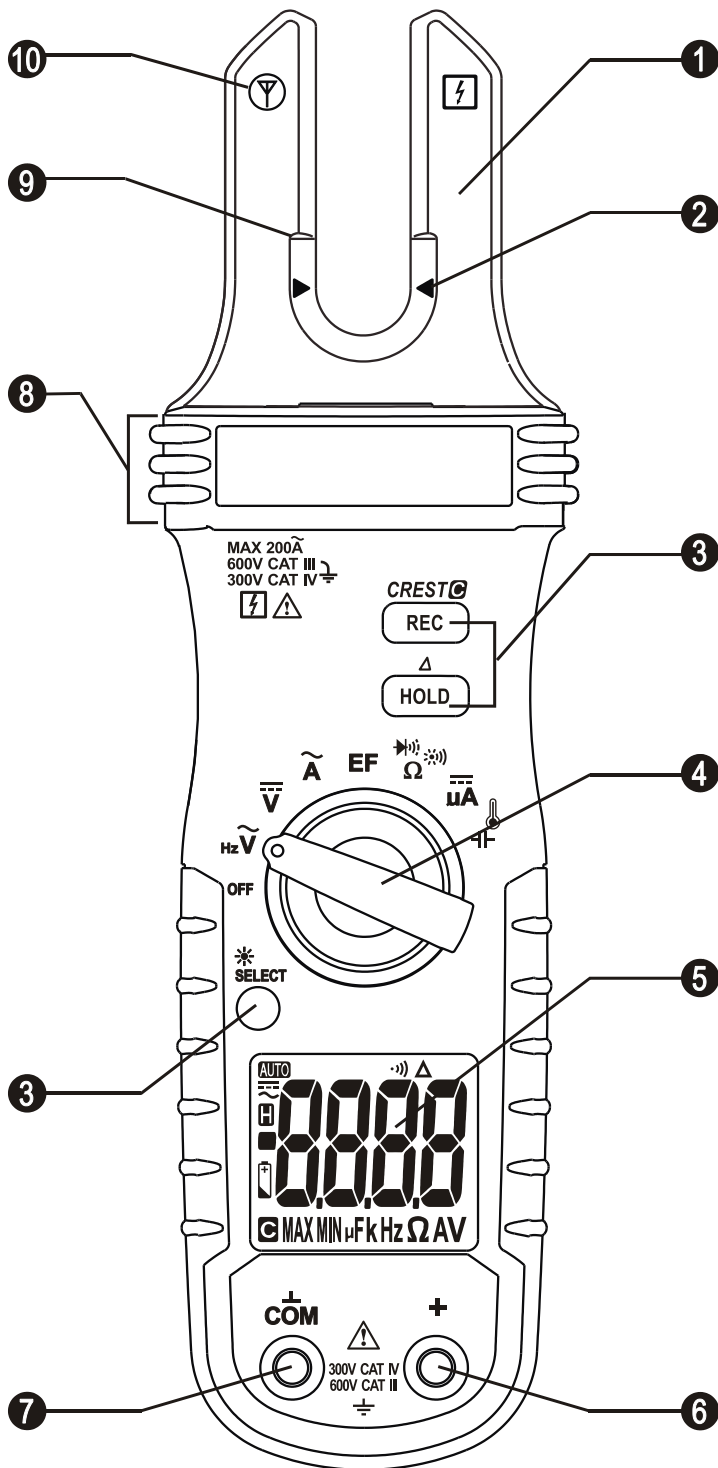

- 1) Fork-clamp for ACA magnetic field pick up
- 2) ACA Magnetic field pick-up center indicator, at where best current accuracy is specified
- 3) Push-buttons for special functions & features.
- 4) Rotary Selector to turn the power ON/OFF and select a function
- 5) 3-5/6 digits 6000 counts numeric LCD display
- 6) Input Jack for all functions EXCEPT Fork-clamp ACA and Non-Contact EF-Detection functions
- 7) Common (Ground reference) Input Jack for all functions EXCEPT Fork-clamp ACA and Non-Contact EF-Detection functions
- 8) Hand/Finger Barrier to indicate the limits of safe access of the meter during Fork-clamp ACA measurements
- 9) ACA Magnetic field pick-up upper limit indicator; below where current accuracy is specified
- 10) Antenna location symbol for Non-Contact EF-Detection

#### 4) OPERATION

##### **WARNING**

Before and after hazardous voltage measurements, test the voltage function on a known source such as line voltage to determine proper meter functioning

## ACV (LPF added), & Line-level Hz (LPF added) (Model 039F only)

Inputs are made via the test lead terminals **COM/+**. Defaults at **ACV** Function. Press the **SELECT** button momentarily to select **Line-level Hz** function.

Note:

**ACV** and **Line-level Hz** functions are bundled with LPF low-pass filter, and are capable of dealing with most **VFD** (Variable Frequency Drives) signals. It also improves reading stability in noisy electrical environments.

## DCV

Inputs are made via the test lead terminals **COM/+**.

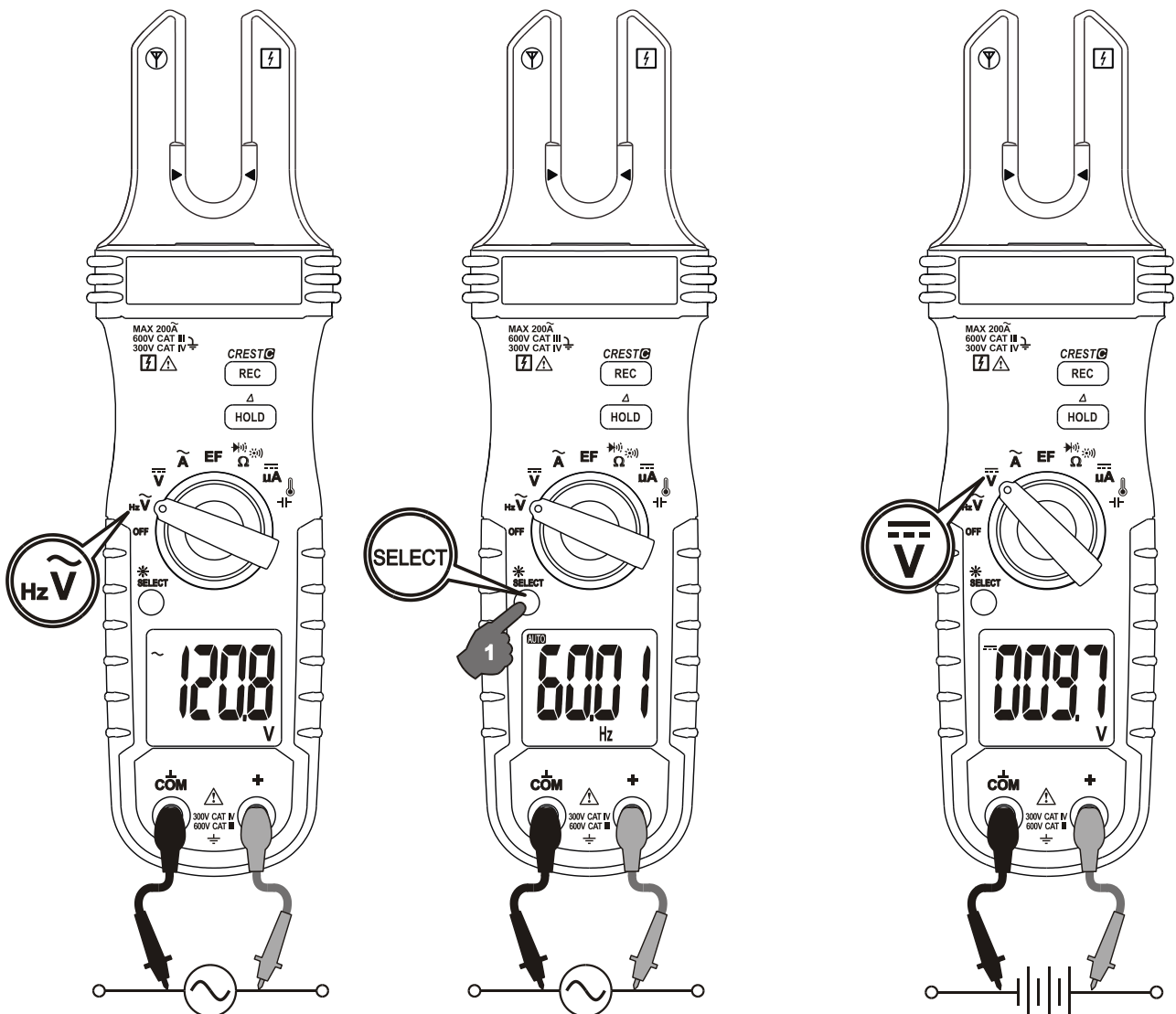

## **Current Measurements: Application & Removal Of The Fork-clamp**

Apply the Fork-clamp around conductor(s) of only one single pole of a circuit for load current measurements. Applying around conductors of more than one pole of a circuit may result in differential current (like identifying leakage current) measurements. Align the conductor(s) to the Fork-clamp center indicators as much as possible to get the best measuring accuracy. For removal, remove the Fork-clamp from the conductor(s).

Adjacent current-carrying devices such as transformers, motors and conductor wires may affect measurement accuracy. Keep the Fork-clamp away from them as much as possible to minimize influence during measurements.

### ***WARNING***

This Fork-clamp meter series is designed to directly apply around or remove from uninsulated hazardous live conductors. But still, individual protective equipment must be used if hazardous live parts in the installation where measurement is to be carried out could be accessible. Do not use the meter to measure currents above the rated frequency (400Hz). Circulating currents may cause the magnetic circuits of the Fork-clamp reach a hazardous temperature.

### **Fork-clamp ACA**

Input is made via the Fork-clamp where best accuracy is specified at the center indicator area.

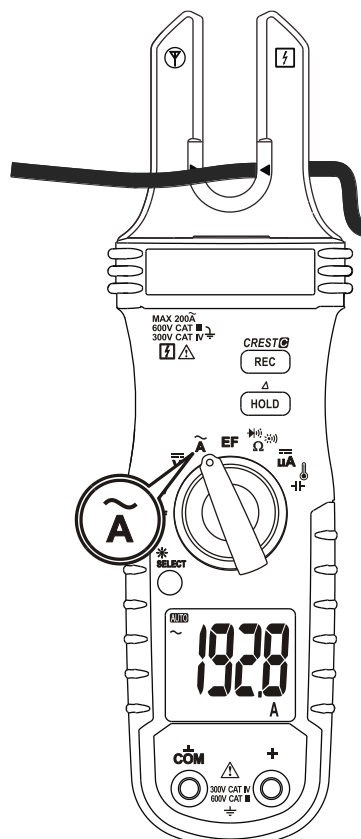

## $\Omega$ Resistance, $\text{BeepLit}^{\text{TM}}$ Continuity, & $\text{BeepLit}^{\text{TM}}$ Diode

Inputs are made via the test lead terminals **COM**/. Defaults at  $\Omega$  Resistance. Press the **SELECT** button momentarily to select the subject functions in sequence.

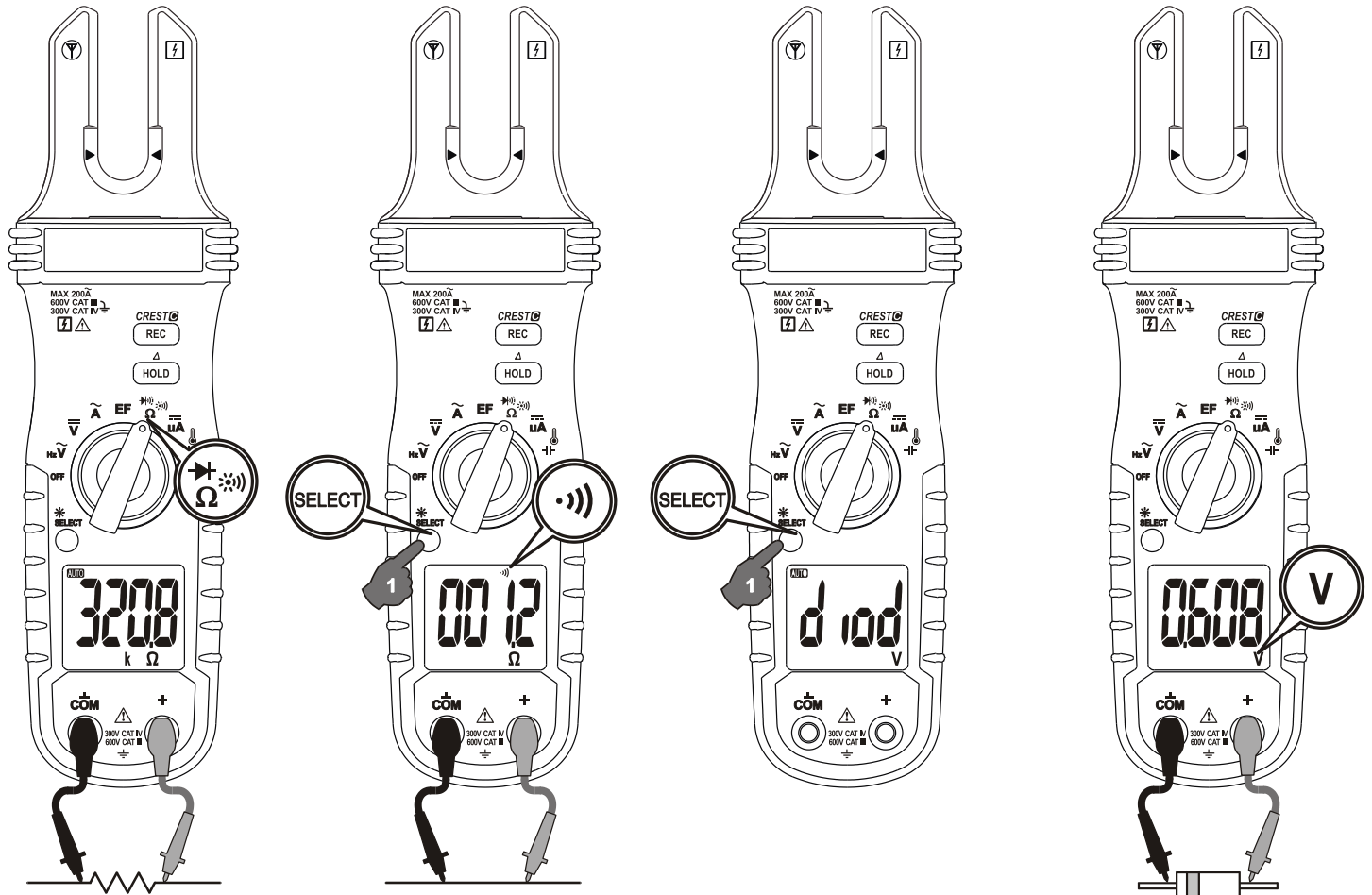

### ⊙ $\text{BeepLit}^{\text{TM}}$ Continuity

This function is having improved convenience for checking wiring connections and operation of switches. Resistance threshold is being used. A continuous beep sound together with display backlight flashing indicates a complete wire. Such audible and visible indications improve continuity readabilities in noisy working environments.

### ⊙ $\text{BeepLit}^{\text{TM}}$ Diode

●**Reading indication:** Forward voltage drop (forward biased) for a good silicon diode is between 0.400V to 0.900V. A higher reading indicates a leaky diode (defective). A zero reading indicates a shorted diode (defective). An over-range display indicates an open diode (defective). Reverse the test leads connections (reverse biased) across the

diode. The digital display shows over-range if the diode is good. Any other readings indicate the diode is resistive or shorted (defective).

● **Beep-Alert & BeepLit™ indication:** When the display reading drops across 0.850V, the meter alerts a short beep sound to signal a reasonable forward voltage drop of common diodes. However, if the reading further drops below 0.100V, the meter gives a continuous beep sound together with the display backlight flashing to indicate a shorted diode or a complete wire. It is similar to that of **BeepLit™ Continuity** function but **BeepLit™ Diode**, instead, is based on voltage threshold to indicate complete wires.

## **CAUTION**

Using **Resistance**, **BeepLit™ Continuity** or **BeepLit™ Diode** function in a live circuit will produce false results and may damage the meter. In many cases, the component(s) under test must be disconnected from the circuit to obtain an accurate measurement reading.

## **EF-Detection of Electric Field**

Defaults at **EF-H**, the High sensitivity. The meter displays “**EF-H**” when it is ready. If it is too sensitive for your applications, press the **SELECT** button momentarily to select **EF-L**, the Low sensitivity. The detected Electric Field strength is indicated as a series of bar-graph segments on the display plus variable beep sounds.

● **Non-Contact EF-Detection (NCV):** An antenna is located along the top-left end of the Fork-clamp, which detects the electric field surrounds energized conductors. It is ideal for tracing live wiring connections, locating wiring breakages and to distinguish between live and earth connections.

● **Probe-Contact EF-Detection (Single-pole):** For more precise indication of live wires, such as distinguishing between Live and Ground connections, use one single test probe to test via terminal **COM** for direct metal contact probing to achieve the most distinctive indications.



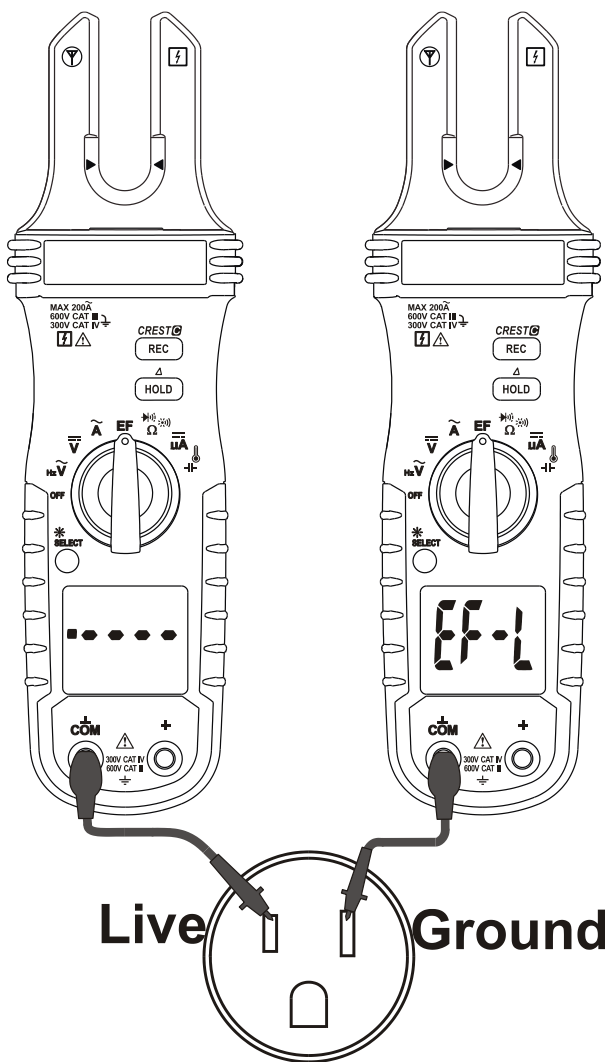
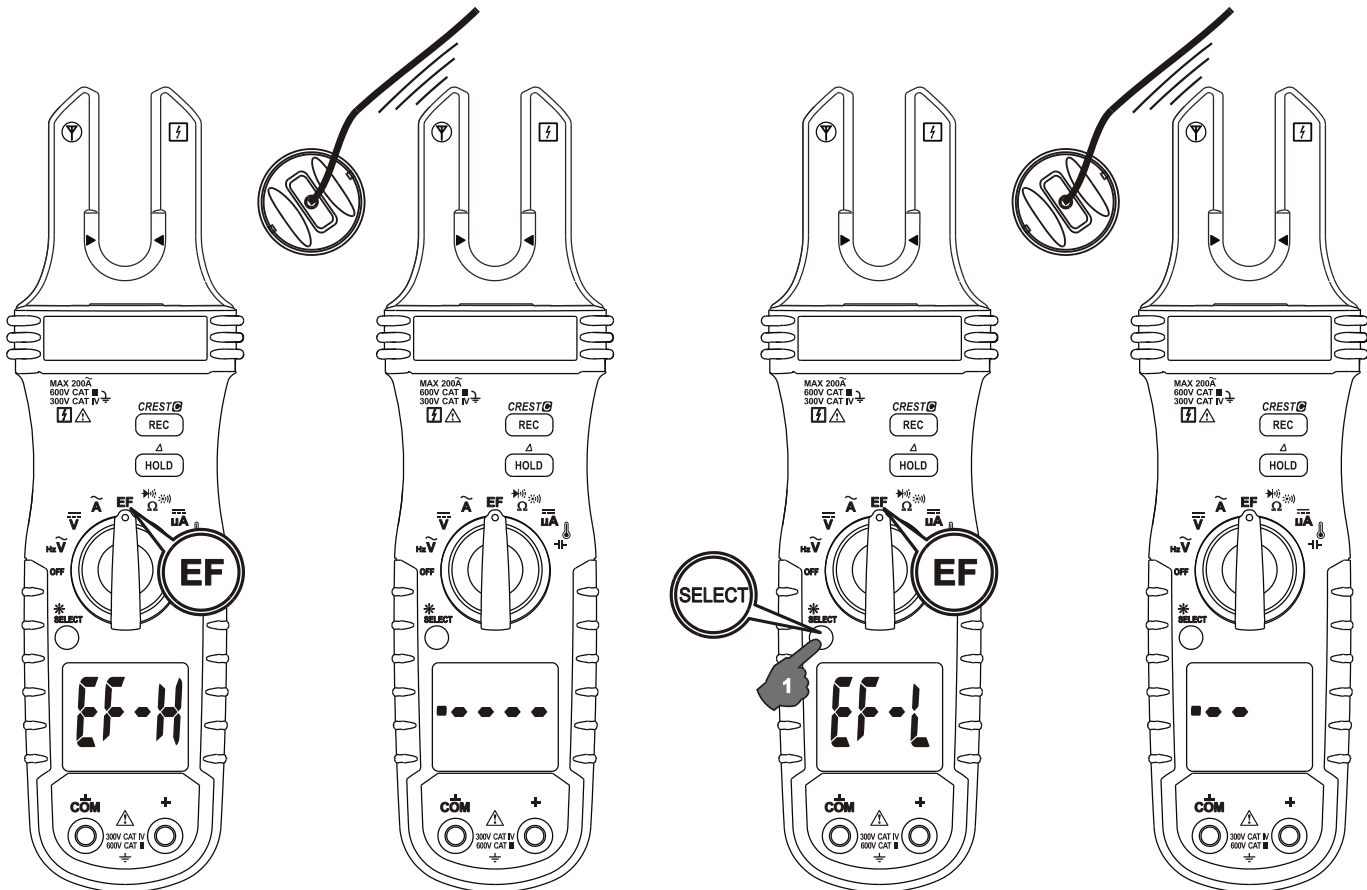

Live Ground

## DC $\mu$ A (Model 039F only)

Inputs are made via the test lead terminals **COM/+**.

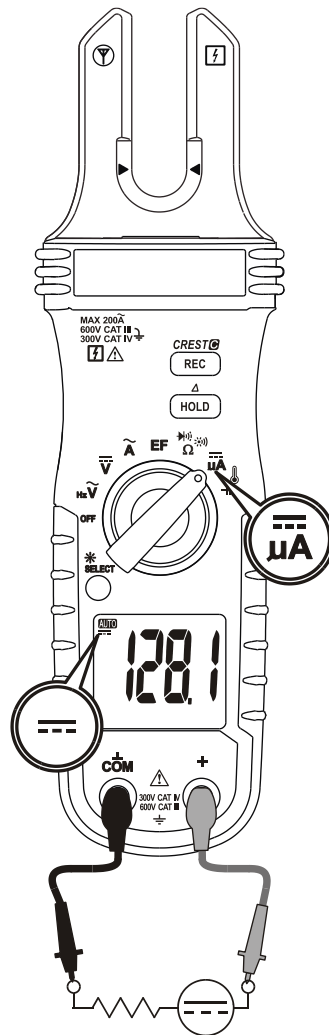

### ● **Application notes:**

The **DC $\mu$ A** function is designed especially for HVAC/R flame sensor applications. The 0.1 $\mu$ A resolution is useful for identifying the minute current changes in flame detector applications. Flame signal current check should indicate steady flame signal of at least 2 $\mu$ A for a rectification type, or 1.5 $\mu$ A for an ultraviolet type (8 $\mu$ A for self checking systems). If a flame signal current with inadequate strength or fluctuation beyond 10%, check the following to avoid the risk of unwanted flame relay dropout :

For gas or oil flames (Minipeeper):

- ✓ Low supply voltage
- ✓ Detector location
- ✓ Defective detector wiring
- ✓ Dirty viewing windows
- ✓ Faulty Minipeeper

*For oil flames (Photocell):*

- ✓ *Detector location & wiring*
- ✓ *Smoky flame or poorly adjusted air shutter*
- ✓ *Faulty Photocell*
- ✓ *Temperature over 165 °F (74 °C) at photocell*

*For gas flames (Flame Rod):*

- ✓ *Ignition interference (A flame signal current difference with the ignition both on and off greater than  $0.5\mu\text{A}$  indicates the presence of ignition interference)*
- ✓ *Insufficient ground (must be at least 4 times the detector area)*
- ✓ *Flame lifting off burner head (ground), or not continuously in contact with the flame rod*
- ✓ *Temperature in excess of 600 °F (316 °C) at the flame electrode insulator causing short to ground.*

## **-H- Capacitance & Temperature (Model 039F only)**

Inputs are made via the test lead terminals **COM/+**. Defaults at **-H- Capacitance**. Press the **SELECT** button momentarily to select **°C** (Celsius) and **°F** (Fahrenheit) in sequence (**°F** selection can be left out as factory calibration default for countries that only accept metric units).

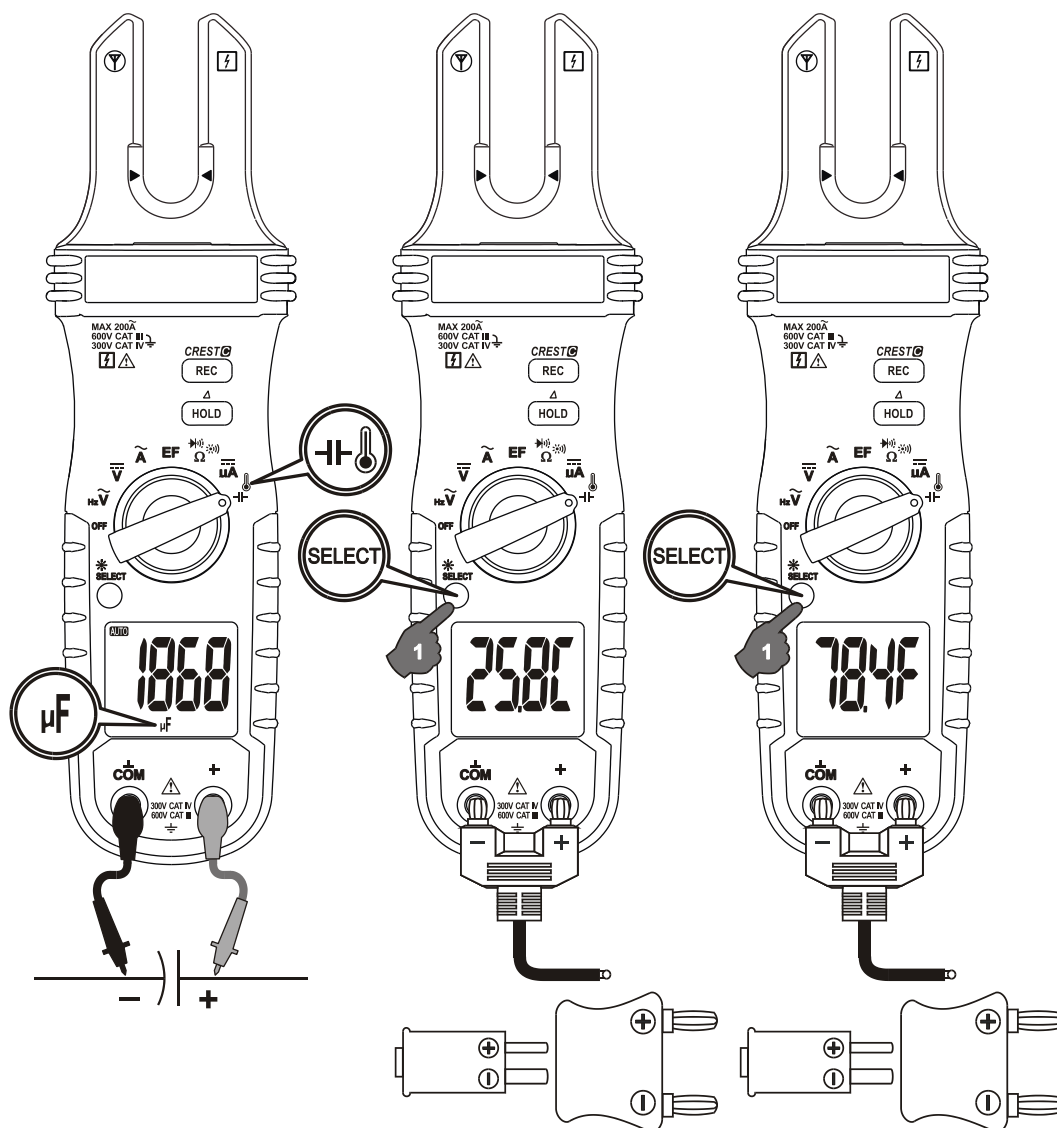

### **CAUTION**

*Discharge capacitor(s) before making capacitance measurements. Large value capacitors should be discharged through an appropriate resistance load. Using Capacitance function in a live circuit will produce false results and may damage the meter. In many cases the suspected component(s) must be disconnected from the circuit to obtain accurate measurement readings.*

**Note**

Be sure to insert the banana-plug type-K temperature bead-probe Bkp60 with correct **+** **-** polarities. Banana-pins to type-K socket adapter Bkb32 (Optional purchase) can be used to accept other type-K probes using standard miniature plugs.

Temperature accuracies assume meter interior has the same temperature (isothermal stage) of the ambient, particularly the plug of the probe being used, for a correct junction voltage compensation. Allow the meter interior temperature to catch up with that of the plug after a sudden change of measuring environment and hence the ambient temperature. This can take up to an hour, for changes  $> 5^{\circ}\text{C}$ , within a low ventilated sturdy meter housing. The uncompensated temperature differences, if any, will be reflected as offsets on the meter readings.

**HOLD**

**HOLD** feature freezes the display for later view. LCD “**H**” turns on. Press the **HOLD** button momentarily to toggle the **HOLD** feature.

**Relative $\Delta$  mode**

**Relative $\Delta$**  mode allows the user to offset the meter consecutive measurements with the main-display displaying reading as the reference value. LCD “ **$\Delta$** ” turns on. Press the  **$\Delta$**  (**HOLD**) button for one second or more to toggle **Relative $\Delta$**  mode.

**RECORD mode**

Press the **REC** button momentarily to activate **MAX/MIN** recording mode. LCD **MAX** & **MIN** turn on. The meter beeps when new **MAX** (maximum) or **MIN** (minimum) reading is updated. Press the button momentarily to read the **MAX**, **MIN**, and **MAXMIN** (active measurement) readings in sequence. Press the button for 1 second or more to exit this mode. Auto-Power-Off is disabled automatically in this mode.

**5ms CREST mode**

Press the **CREST** button for one second or more to activate **CREST** mode (Instantaneous PEAK-HOLD) to capture current or voltage peak values in duration as short as 5ms. LCD **C** & **MAX** turn on. The meter beeps when new **C**MAX**** (+Peak) or **C**MIN**** (-Peak) reading is updated. Press the button momentarily to toggle the **C**MAX**** and **C**MIN**** readings. Press the button for 1 second or more to exit this mode. Auto-Power-Off is disabled automatically in this mode.

### **LCD Backlight and Auto-Backlight-Off (ABO)**

Press the **SELECT** button for 1 second or more to toggle the LCD backlight. The **ABO** mode turns the LCD backlight off automatically after 10 minutes of backlight activation to extend battery life. See **Power-on Options** section for disabling **ABO**.

### **Intelligent Auto-Power-Off (APO)**

The **APO** mode turns the meter off automatically to extend battery life after idling 32 minutes of no specified activities, where applicable, below:

- 1) Rotary switch or push button operations
- 2) Significant measuring readings of above 8.5% of ranges
- 3) Non-over-range readings for Resistance, Continuity or Diode function
- 4) Non-zero readings for Hz function

In other words, the meter will intelligently reset the **APO** mode when it is under normal measurements. To wake up the meter from **APO**, press the **SELECT** button momentarily and release, or turn the rotary switch OFF and then back on. Always turn the rotary switch to the OFF position when the meter is not in use.

### **Power-on Options**

#### **☉ Disabling APO and ABO**

Press and hold the **SELECT** button while powering on the meter can disable both **APO** and **ABO** features temporarily during the power on session. The LCD will display “**dAPO**” to confirm selection before the **SELECT** button is released.

#### **☉ Shortening APO idling time for inspection**

Press and hold the **HOLD** button while powering on the meter can shorten the **APO** idling time to 5 seconds temporarily during the power on session. It is designed mainly for production inspection.

#### **☉ Showing all LCD segments for inspection**

Press and hold the **REC** button while powering on the meter can hold and show all LCD segments before the button is released. It is designed mainly for production inspection.

## **5) MAINTENANCE**

### ***WARNING***

To avoid electrical shock, disconnect the meter from any circuit, remove the test leads from the input jacks and turn OFF the meter before opening the case. Do not operate with open case.

## Trouble Shooting

If the instrument fails to operate, check batteries and test leads etc., and replace as necessary. Double check operating procedure as described in this user's manual. Refer to the LIMITED WARRANTY section for obtaining calibration, repairing or warranty service.

## Accuracy and Calibration

Accuracy is specified for a period of one year after calibration. Periodic calibration at intervals of one year is recommended to maintain meter accuracy.

## Cleaning and Storage

Periodically wipe the meter and the test probe assembly with a damp cloth and mild detergent. Do not use abrasives or solvents. Allow to dry completely before operating. If the meter is not to be used for periods of longer than 60 days, remove the batteries and store them separately.

## Battery replacement

The meter uses standard 1.5V AAA Size (IEC R03) battery X 2

Loosen the 2 captive screws from the bottom case. Lift the bottom case. Replace the batteries. Put back the bottom case. Re-fasten the screws.

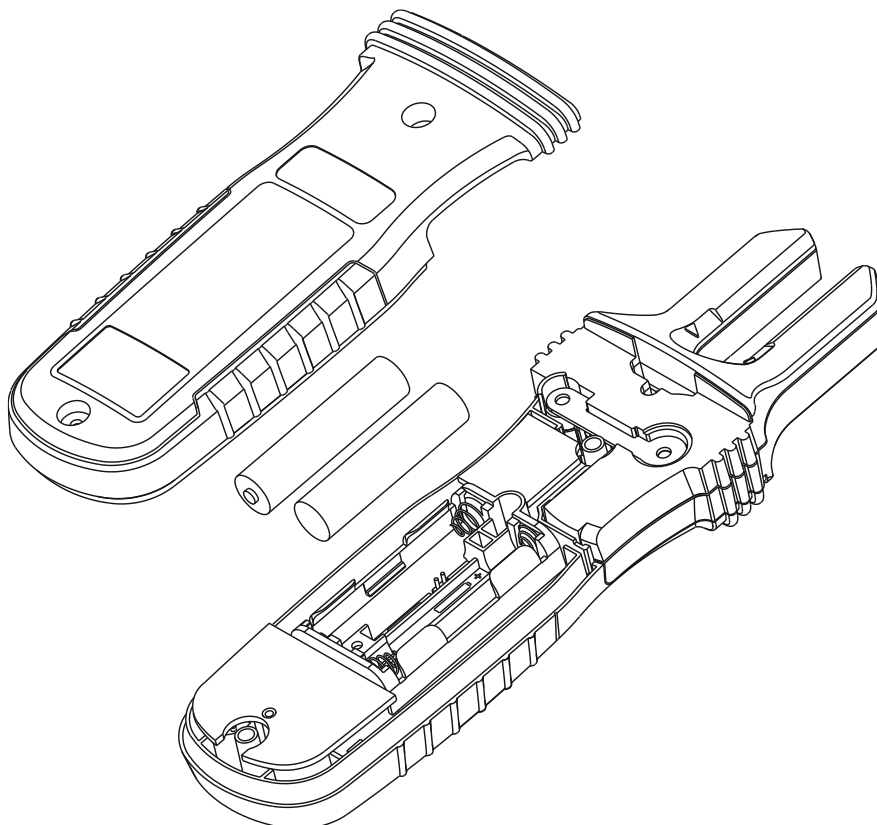

## GENERAL SPECIFICATIONS

**Display:** 3-5/6 digits 6000 counts

**Polarity:** Automatic

**Update Rate:** 5 per second nominal

**Operating Temperature:** 0°C to 40°C

**Relative Humidity:** Maximum relative humidity 80% for temperature up to 31°C decreasing linearly to 50% relative humidity at 40°C

**Pollution degree:** 2

**Storage Temperature:** -20°C to 60°C, < 80% R.H. (with battery removed)

**Altitude:** Operating below 2000m

**Temperature Coefficient:** nominal  $0.1 \times (\text{specified accuracy}) / ^\circ\text{C} @ (0^\circ\text{C} -- 18^\circ\text{C} \text{ or } 28^\circ\text{C} -- 40^\circ\text{C})$ , or otherwise specified

**Sensing:** True RMS

**Safety:** Certified per IEC/EN/CSA\_C22.2\_No./UL standards: 61010-1 Ed. 3.0, 61010-2-032 Ed. 3.0, 61010-2-033 Ed. 1.0, & 61010-031 Ed. 2.0 to Measurement Categories CAT III 600V and CAT IV 300V ac & dc

**Transient Protection:** 6.0kV (1.2/50 $\mu$ s surge)

### Overload Protections:

Current via Fork-clamp: 200Aac rms at <400Hz

Voltage via terminals: 660Vdc / 920Vac rms

Other functions via terminals: 600Vdc/Vac rms

### E.M.C.: Meets EN61326-1:2013

ACA Functions, in an RF field of 1V/m:

Total Accuracy = Specified Accuracy + 40 digits at around 87MHz

DC $\mu$ A and Ohm Functions, in an RF field of 1V/m:

Total Accuracy = Specified Accuracy + 25 digits

Other Functions, in an RF field of 3V/m:

Total Accuracy = Specified Accuracy + 20 digits

**Power Supply:** 1.5V AAA Size battery X 2

**Power Consumption:** Typical 4mA

### Low Battery Indication:

Below approx. 2.85V for Capacitance & Hz

Below approx. 2.5V for other functions

**APO Timing:** Idle for 32 minutes

**APO Consumption:** 5 $\mu$ A typical

**Dimension (LxWxH):** 193 x 57 x 32mm

**Weight:** 158g



**Fork-clamp opening & Conductor diameter:** 12.5mm max

**Fork-clamp probe width:** 12mm approx

**Accessories:** Test lead set, User's manual, Soft carrying pouch, Bkp60 banana-plug type-K thermocouple (Model 039F only)

**Optional purchase accessories:** BKB32 banana-plug to type-K socket plug adaptor (Model 039F only)

**Special Features:** Fork-clamp Current Measurement; MAX/MIN Recording mode; MAX/MIN Crest (Peak-Hold) mode; Relative-Zero mode; Display Hold; EF-Detection (NCV & Single pole); BeepLit™ Feature

## Electrical Specifications

Accuracy is  $\pm$ (% reading digits + number of digits) or otherwise specified, at 23°C  $\pm$  5°C.

Maximum Crest Factor < 2 : 1 at full scale & < 4 : 1 at half scale or otherwise specified, and with frequency spectrum not exceeding the specified frequency bandwidth for non-sinusoidal waveforms.

## DC Voltage

RANGE	Accuracy
600.0V	1.0% + 5d

Input Impedance: 10M $\Omega$ , 100 pF nominal

## AC Voltage (LPF added)

RANGE	Accuracy
50Hz ~ 60Hz	
600.0V	1.5% + 5d

Input Impedance: 10M $\Omega$ , 100 pF nominal

## CREST (Peak-Hold)

Applicability: Voltage and Non-invasion Current functions

Accuracy: Add +/- 250 digits to specified accuracy for changes > 5ms in duration

## BeepLit™ Continuity Tester

Continuity Threshold: Between 30 $\Omega$  and 480 $\Omega$

Continuity ON Response Time: 15ms approx.

Audible Indication: Beep sound

Visible Indication: LCD Backlight

**Ohm**

RANGE	Accuracy
600.0Ω, 6.000kΩ (All models)	1.0% + 5d
60.00kΩ, 600.0kΩ, 6000kΩ (Model 039F only)	

Open Circuit Voltage: 1.0VDC typical

**Capacitance (Model 039F only)**

RANGE	Accuracy <sup>1)</sup>
200.0μF, 2500μF	2.0% + 4d

<sup>1)</sup>Accuracies with film capacitor or better

**BeepLit™ Diode Tester**

RANGE	Accuracy
3.000V	1.5% + 5d

Test Current: 0.3mA typical

Open Circuit Voltage: < 3.5VDC typical

Beep-Alert Threshold: Drop across 0.850V

BeepLit™ ON Threshold: < 0.100V

Audible Indication: Beep sound

Visible Indication: LCD Backlight

**DCμA (Model 039F only)**

RANGE	Accuracy	Burden Voltage
200.0μA, 2000μA	1.0% + 5d	3.5mV/μA

**Temperature (Model 039F only)**

RANGE	Accuracy <sup>1) 2)</sup>
-40.0 °C ~ 99.9 °C	1.0% + 1°C
100 °C ~ 400 °C	
-40.0 °F ~ 211.8 °F	1.0% + 2°F
212 °F ~ 752 °F	

<sup>1)</sup>Accuracies assume meter interior has the same temperature (isothermal stage) of the ambient for a correct junction voltage compensation. Allow the meter and the type-K probe set to reach isothermal stage for a significant change of ambient temperature. It can take up to an hour for changes > 5°C.

<sup>2)</sup>Type-K thermocouple range & accuracy not included

## Fork-clamp ACA

RANGE	Accuracy <sup>1)</sup>
50Hz ~ 60Hz	
60.00A <sup>2)</sup> , 200.0A	2.0% + 5d
45Hz ~ 400Hz	
60.00A <sup>2)</sup> , 200.0A	3.0% + 5d

<sup>1)</sup>Induced error from adjacent current-carrying conductor: <0.08A/A

<sup>2)</sup>60.00A range measurement available from 0.10A

## Hz (LPF added) Line-Level Frequency (Model 039F only)

Function	Sensitivity <sup>1)</sup> (Sine RMS)	Range
600Vac	50V	5.00Hz ~ 999.9Hz

Accuracy: 1%+5d

<sup>1)</sup>DC-bias, if any, not more than 50% of Sine RMS

## Non-Contact EF-Detection (NCV)

Bar-Graph Indication	EF-H (Hi Sensitivity)	EF-L (Lo Sensitivity)
	Typical AC Voltage (Tolerance)	
-	10V (2V ~ 20V)	40V (10V ~ 70V)
--	20V (4V ~ 40V)	80V (20V ~ 140V)
---	40V (8V ~ 70V)	160V (40V ~ 280V)
----	80V (16V ~ 140V)	320V (80V ~ 560V)
-----	160V (40V ~ 600V)	500V (160V ~ 600V)

Indication: Bar-graph segments & audible beep tones proportional to the field strength

Detection Frequency: 50/60Hz

Detection Antenna: Inside the top-left end of the Fork-clamp.

**Probe-Contact EF-Detection (Single-pole Measurement):** For more precise indication of live wires, such as distinguishing between live and ground connections, use one single test probe to test via terminal COM for direct metal contact probing to achieve the most distinctive indications.

## LIMITED WARRANTY

BRYMEN warrants to the original product purchaser that each product it manufactures will be free from defects in material and workmanship under normal use and service within a period of one year from the date of purchase. BRYMEN's warranty does not apply to accessories, fuses, fusible resistors, spark gaps, varistors, batteries or any product which, in BRYMEN's opinion, has been misused, altered, neglected, or damaged by accident or abnormal conditions of operation or handling.

To obtain warranty service, contact your nearest BRYMEN authorized agent or send the product, with proof of purchase and description of the difficulty, postage and insurance prepaid, to BRYMEN TECHNOLOGY CORPORATION. BRYMEN assumes no risk for damage in transit. BRYMEN will, at its option, repair or replace the defective product free of charge. However, if BRYMEN determines that the failure was caused by misused, altered, neglected, or damaged by accident or abnormal conditions of operation or handling, you will be billed for the repair.

THIS WARRANTY IS EXCLUSIVE AND IS IN LIEU OF ALL OTHER WARRANTIES, EXPRESSED OR IMPLIED, INCLUDING BUT NOT LIMITED TO ANY IMPLIED WARRANTY OR MERCHANTABILITY OR FITNESS FOR A PARTICULAR PURPOSE OR USE. BRYMEN WILL NOT BE LIABLE FOR ANY SPECIAL, INDIRECT, INCIDENTAL OR CONSEQUENTIAL DAMAGES.



BRYMEN TECHNOLOGY CORPORATION

TEL:+886 2 2226 3396

FAX:+886 2 2225 0025

<http://www.brymen.com>



PRINTED ON RECYCLABLE PAPER, PLEASE RECYCLE

COPYRIGHT © MMXX Btc,

ALL RIGHTS RESERVED

P/N: 7M1C-1581-0000

PRINTED IN TAIWAN