

USER'S MANUAL

BM173D

BM175D

BM176D

**AC Clamp-on
Multimeter Series**



1) SAFETY

This manual contains information and warnings that must be followed for operating the meter safely and maintaining the meter in a safe operating condition. If the meter is used in a manner not specified by the manufacturer, the protection provided by the meter may be impaired.

TERMS IN THIS MANUAL

WARNING identifies conditions and actions that could result in serious injury or even death to the user.

CAUTION identifies conditions and actions that could cause damage or malfunction in the instrument.

WARNING

To reduce the risk of fire or electric shock, do not expose this product to rain or moisture. The meter is intended only for indoor use.

Keep your hands/fingers behind the hand/finger barriers (of the meter and the test probe assembly, where applicable) that indicate the limits of safe access of the hand-held parts during measurements. Inspect lead wires, connectors, and probes for damaged insulation or exposed metal before using the meter. If any defects are found, replace them immediately. Only use the probe assembly provided with the meter or a UL Listed Probe Assembly to the same meter ratings or better.

IEC 61010-031 requires exposed conductive test probe tips to be $\leq 4\text{mm}$ for CAT III & CAT IV ratings. Refer to the category markings on your probe assemblies as well as on the add-on accessories (like detachable Caps or Alligator Clips), if any, for applicable rating changes.











Observe proper safety precautions when working with voltages above 33 Vrms, 46.7 Vpeak or 70 VDC. These voltage levels pose a potential shock hazard to the user. Before and after hazardous voltage measurements, check the voltage function on a known source such as line voltage to determine proper meter functioning.

This Clamp-on meter is designed to directly apply around or remove from uninsulated hazardous live conductors. But still, individual protective equipment must be used if hazardous live parts in the installation where measurement is to be carried out could be accessible.

CAUTION

Disconnect the meter from the test points before changing meter functions.

INTERNATIONAL SYMBOLS

	Marking of Electrical and Electronic Equipment (EEE). Do not dispose of this product as unsorted municipal waste. Contact a qualified recycler
	Caution! Refer to the explanation in this Manual
	Caution! Possibility of electric shock
	Earth (Ground)
	Meter protected throughout by Double Insulation or Reinforced insulation
	Fuse
	Direct Current (DC)
	Alternating Current (AC)
	Three-phase Alternating Current
	Application around and removal from hazardous live conductors is permitted

Brief Information about Measurement Categories

Measurement Category IV is applicable to test and measuring circuits connected at the source of the building's low-voltage MAINS installation. Examples are measurements on devices installed before the main fuse or circuit breaker in the building installation.

Measurement Category III is applicable to test and measuring circuits connected to the distribution part of the building's low-voltage MAINS installation. Examples are measurements on distribution boards (including secondary meters), circuit-breakers, wiring, including cables, bus-bars, junction boxes, switches, socket-outlets in the fixed installation, and equipment for industrial use and some other equipment such as stationary motors with permanent connection to the fixed installation.

Measurement Category II is applicable to test and measuring circuits connected directly to utilization points (socket outlets and similar points) of the low-voltage MAINS installation. Examples are measurements on MAINS CIRCUITS of household appliances, portable tools and similar equipment.

2) CENELEC Directives

The instruments conform to CENELEC Low-voltage directive 2006/95/EC, Electromagnetic compatibility directive 2004/108/EC and RoHS directive 2011/65/EU.

3) PRODUCT DESCRIPTION

This user's manual uses only representative model(s) for illustrations. Please refer specification details for function availability to each model.

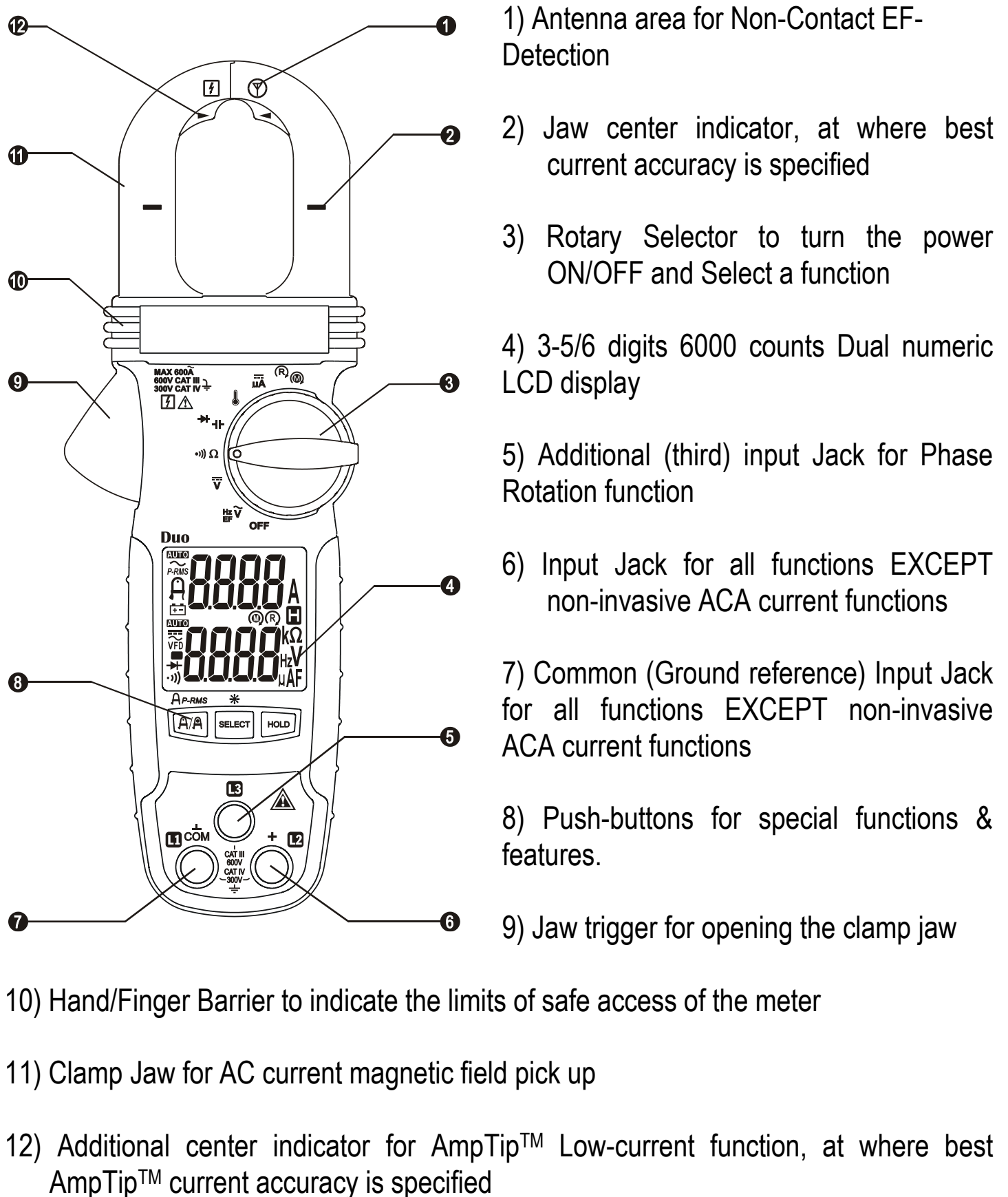

4) OPERATION

Introduction

To realize swift simultaneous dual measurements, the meter uses two Analog-to-Digital Converters (Duo) for its **Clamp-on ACA** functions (Upper-display readings) as well as its **Rotary-switch** functions (Lower-display readings) separately. **Clamp-on ACA** functions turn ON whenever the **Rotary-switch** function is turned ON.

Regular & AmpTip™ Clamp-on ACA functions

Defaults at **Regular ACA** function where best accuracy is specified at the jaw center area. Press **A/A** button momentarily to toggle to **AmpTip™ ACA** function where best accuracy is specified near the jaw tip area for low-current small conductors below 10mm in diameter.

WARNING: Do not use the meter to measure currents above the rated frequency (400Hz). Circulating currents may cause the magnetic circuits of the Jaws reach a hazardous temperature.

CAUTION: (Application and Removal of the Clamp-on Jaws) Press the jaw trigger and clamp the jaws around conductor(s) of only one single pole of a circuit for load current measurements. Make sure the jaws are completely closed, or else it will introduce measurement errors. Enclosing conductor(s) of more than one pole of a circuit may result in differential current (like identifying leakage current) measurements. Align the conductor(s) to the Jaws center indicators (Regular or AmpTip™ indicators where applicable) as much as possible to get the best measuring accuracy. For removal, press the jaw trigger and remove the jaws from the conductor(s).

CAUTION: Adjacent current-carrying devices such as transformers, motors and conductor wires may affect measurement accuracy. Keep the jaws away from them as much as possible to minimize influence.

ACV, Line-Level Hz & EF-Detection (NCV) functions

Inputs, other than that of **EF-Detection** as described later on, are made via the test lead terminals **COM/+**. Defaults at **ACV** Function. Press **SELECT** button momentarily to select **ACV, Hz, EF-H & EF-L** functions in sequence.

WARNING: Before and after hazardous voltage measurements, test the voltage function on a known source such as line voltage to determine proper meter functioning.

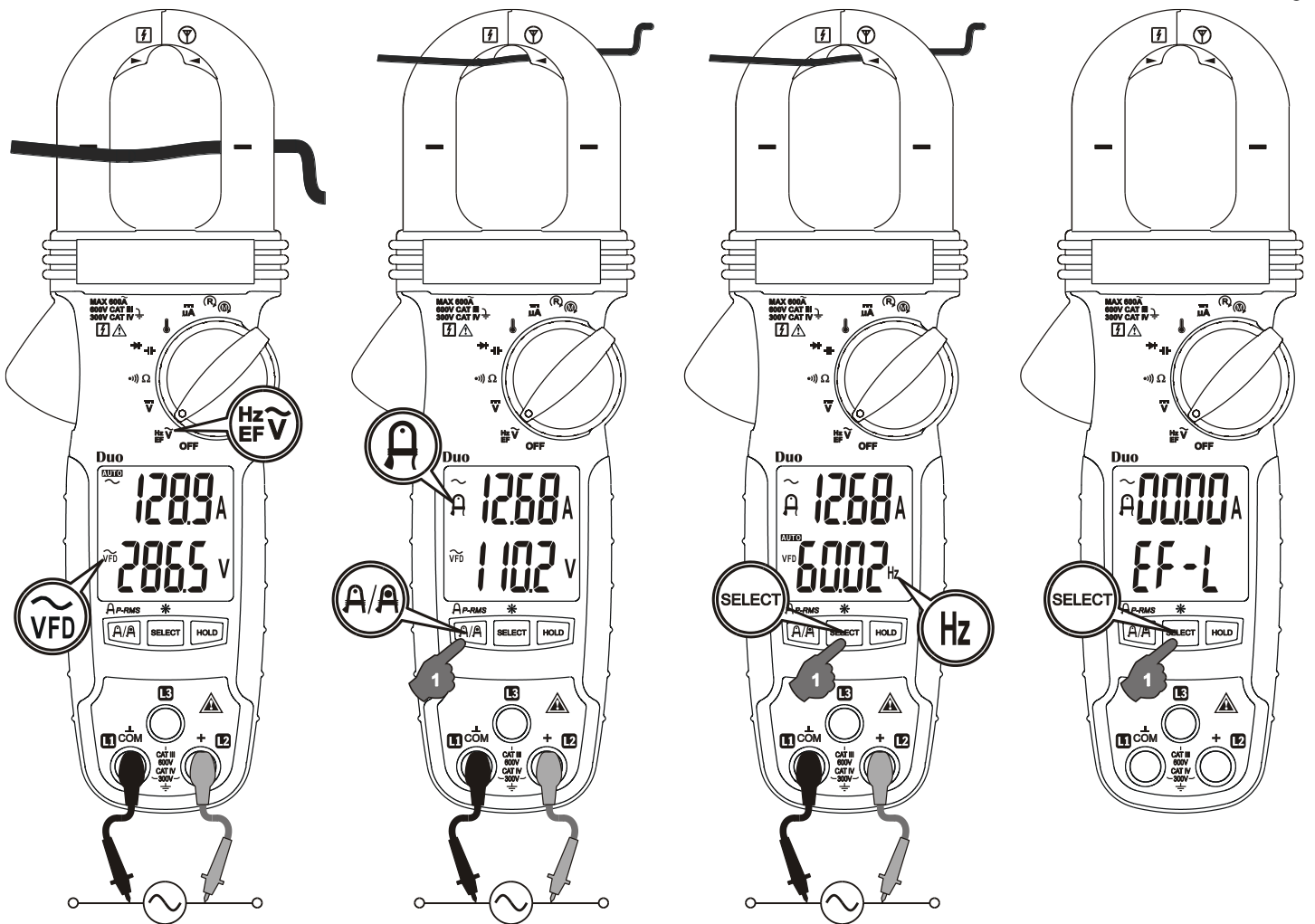

Note:

ACV and **Hz** functions are equipped with digital low-pass filter, and are capable of dealing with **VFD** (Variable Frequency Drives) signals for fundamental readings. It also improves ACV and Hz reading stability being in most noisy electrical environments.

EF-Detection function with EF-H & EF-L Sensitivities

The detected Electric Field strength is indicated as a series of bar-graph segments on the display together with variable beep tones. Two user selectable sensitivities are available. In High Sensitivity range, the meter displays “**EF-H**” when it is ready. It is set to better detect lower voltage signals. If it is too sensitive for your applications, press **SELECT** button momentarily to use the Lower Sensitivity “**EF-L**” range.

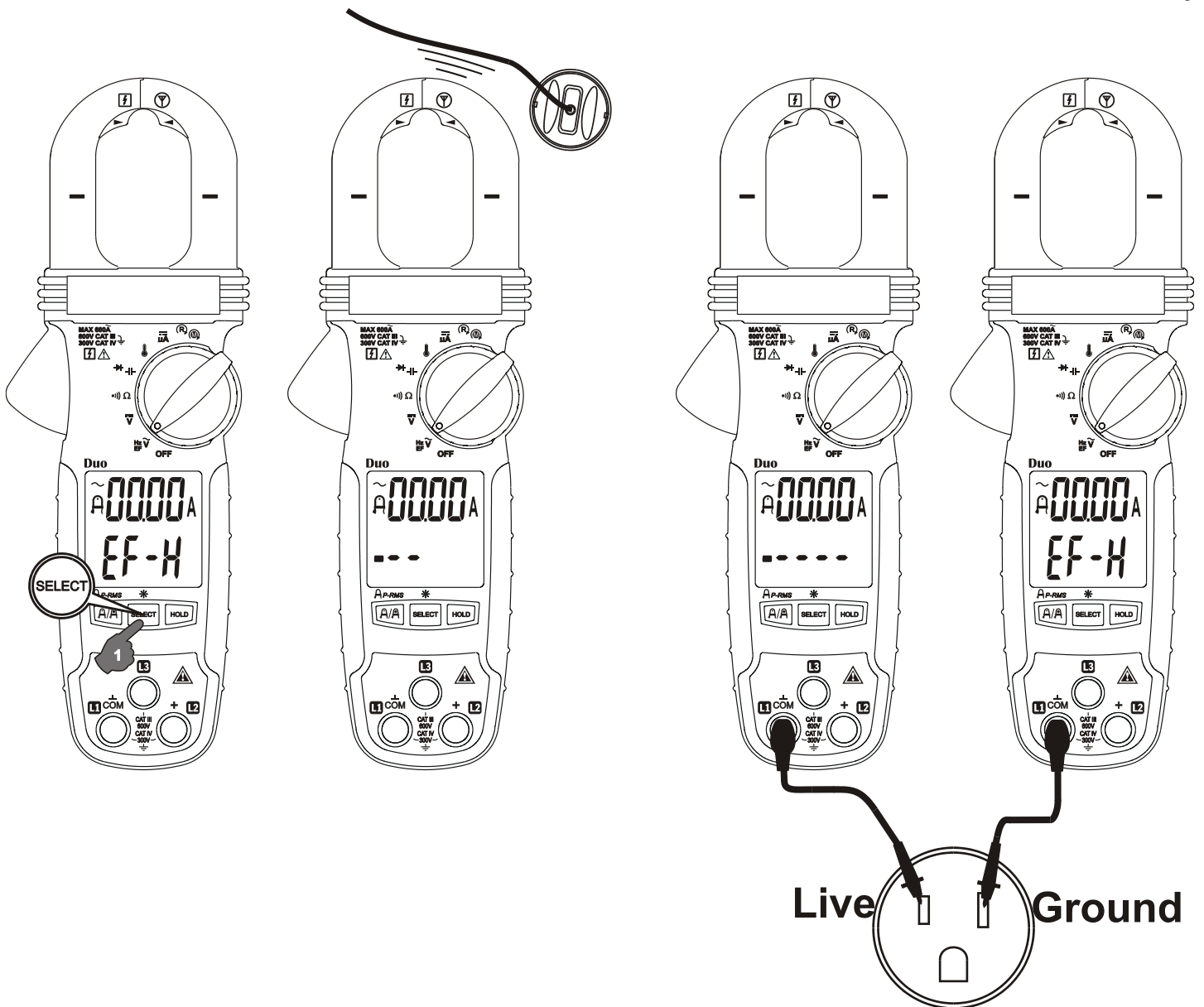

● **Non-Contact EF-Detection (NCV):** An antenna is located along the top-right end of the stationary clamp jaw, which detects electric field surrounding energized conductors. It is ideal for tracing live wiring connections, locating wiring breakages and to distinguish between live and earth connections.

● **Probe-Contact EF-Detection:** For more precise indication of live wires, such as distinguishing between Live and Ground connections, use direct contact testing with one single test-probe via an input terminal. The COM terminal (Black) has the best sensitivity.

DCV function

Inputs are made via the test lead terminals **COM/+**.

WARNING: Before and after hazardous voltage measurements, test the voltage function on a known source such as line voltage to determine proper meter functioning.

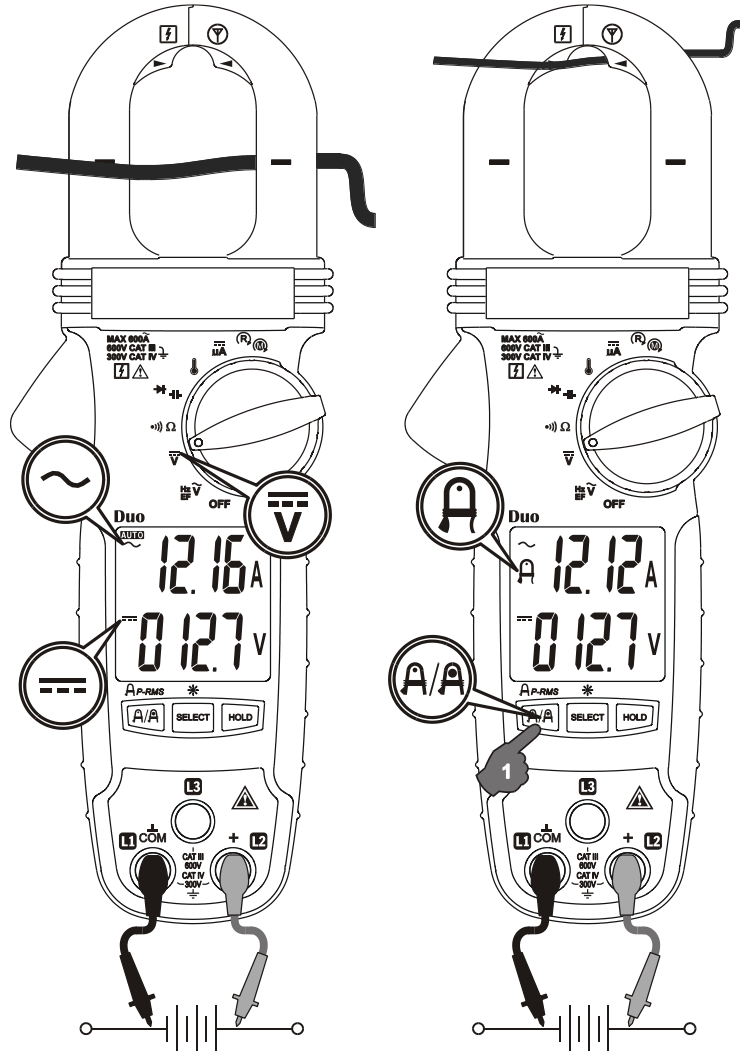

Ω Resistance & $\cdot\cdot\cdot\cdot\cdot$ Continuity functions

Inputs are made via the test lead terminals **COM/+**. Defaults at Ω Resistance. Press **SELECT** button momentarily to toggle between the subject functions.

$\cdot\cdot\cdot\cdot\cdot$ Continuity function is convenient for checking wiring connections and operation of switches. The meter provides Audible as well as Visible results. A continuous beep tone, together with two flashing LCD icons $\cdot\cdot\cdot\cdot\cdot$ and Ω , indicates a complete wire. This further improves ease of use especially in noisy working environments.

CAUTION

Using Resistance or Continuity function in a live circuit will produce false results and may damage the meter. In many cases, the suspected component(s) must be disconnected from the circuit to obtain an accurate measurement result.

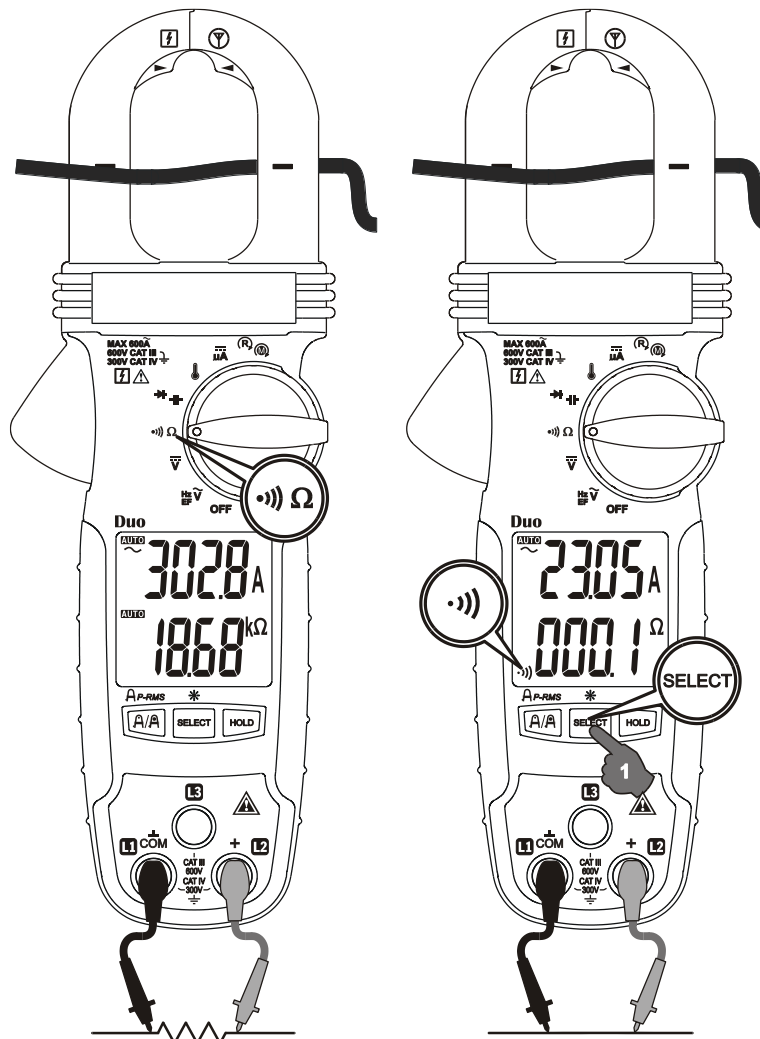

⚡ Capacitance & ➡ Diode functions

Inputs are made via the test lead terminals **COM/+**. Defaults at **⚡ Capacitance**. Press **SELECT** button momentarily to toggle between the subject functions. (For Model 173D, Capacitance and Diode functions are located in different rotary switch positions.)

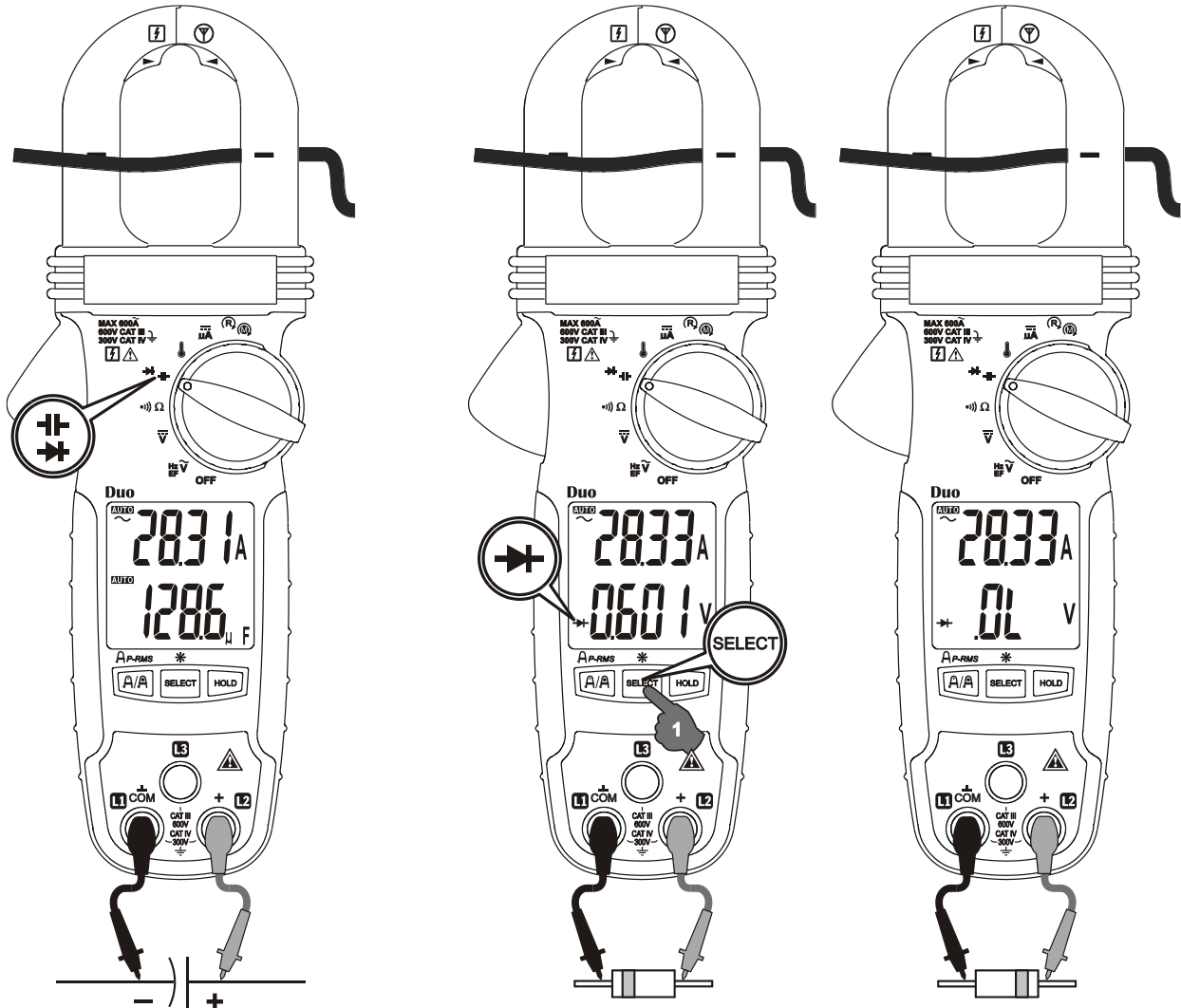

Note

When using Diode test function, normal forward voltage drop (forward biased) for a good silicon diode is between 0.400V to 0.900V. A reading higher than that indicates a leaky diode (defective). A zero reading indicates a shorted diode (defective). An OL indicates an open diode (defective). Reverse the test leads connections (reverse biased) across the diode. The digital display shows OL if the diode is good. Any other readings indicate the diode is resistive or shorted (defective).

CAUTION

1. Using Capacitance or Diode function in a live circuit will produce false results and may damage the meter. In many cases, the suspected component(s) must be

disconnected from the circuit to obtain an accurate measurement reading.

2. When using Capacitance function, discharge capacitor(s) before making any measurements. Large value capacitors should be discharged through an appropriate resistance load

Temperature function (Models 176D & 175D only)

Inputs are made via the test lead terminals **COM/+**. Press **SELECT** button momentarily to toggle between °C (Celsius) and °F (Fahrenheit).

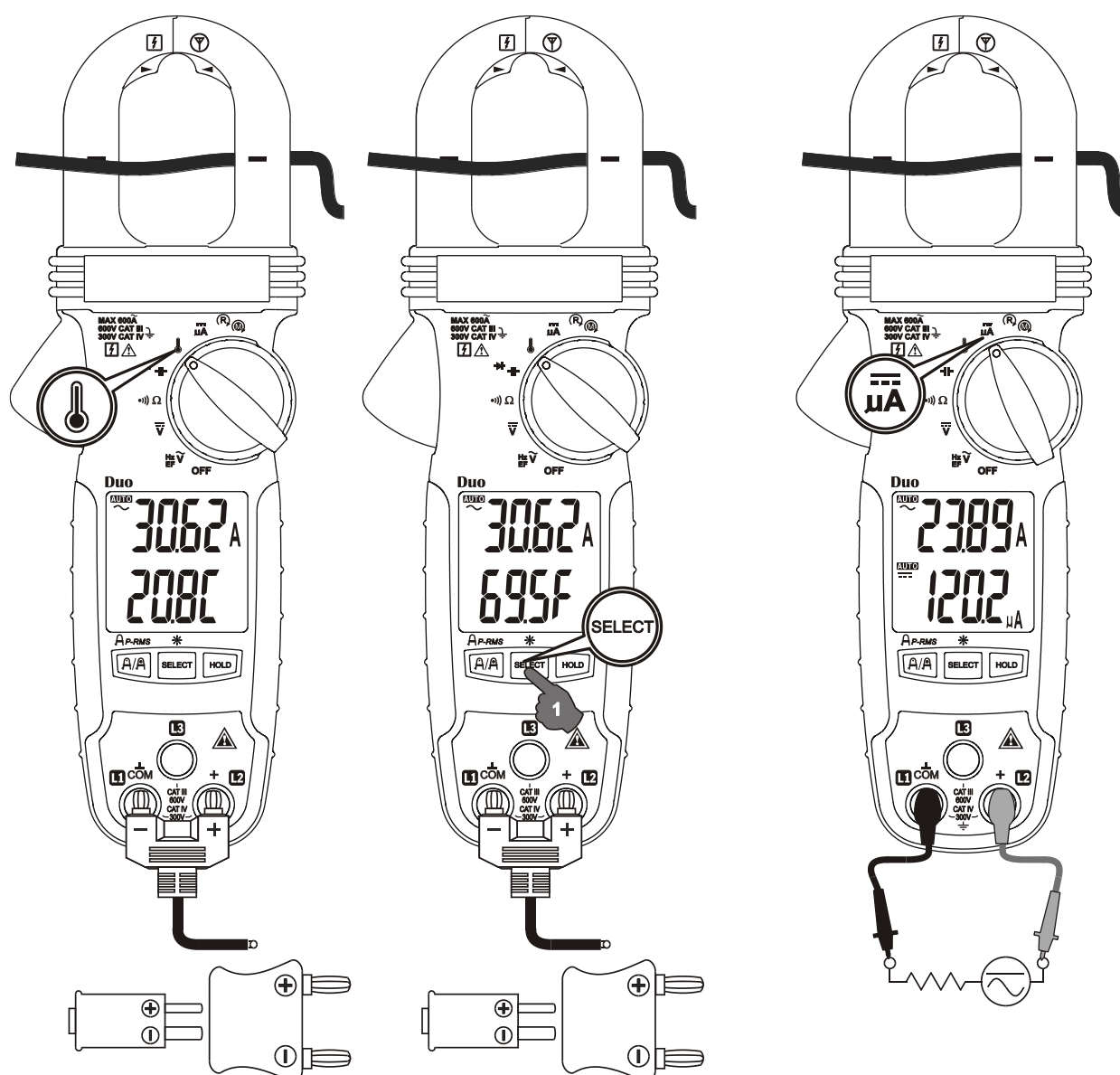

Note

Be sure to insert the banana plug type-K temperature bead probe Bkp60 with correct **+** **-** polarities. You can also use a plug adapter Bkb32 (Optional purchase) with banana pins to type-K socket to adapt other type-K standard mini plug temperature probes.

DC μ A Current function (Models 176D & 175D only)

Inputs are made via the test lead terminals **COM/+**.

Application Notes on Flame Sensors:

The **DC μ A** function is designed especially for HVAC/R flame sensor applications. The 0.1 μ A resolution is useful for identifying the minute current changes in flame detector applications. Flame signal current check should indicate steady flame signal of at least 2 μ A for a rectification type, or 1.5 μ A for an ultraviolet type (8 μ A for self checking systems). If a flame signal current with inadequate strength or fluctuation beyond 10%, check the following to avoid the risk of unwanted flame relay dropout:

For gas or oil flames (Minipeeper):

- Low supply voltage
- Detector location
- Defective detector wiring
- Dirty viewing windows
- Faulty Minipeeper

For oil flames (Photocell):

- Detector location & wiring
- Smoky flame or poorly adjusted air shutter
- Faulty Photocell
- Temperature over 165 °F (74 °C) at photocell

For gas flames (Flame Rod):

- Ignition interference (A flame signal current difference with the ignition both on and off greater than 0.5 μ A indicates the presence of ignition interference)
- Insufficient ground (must be at least 4 times the detector area)
- Flame lifting off burner head (ground), or not continuously in contact with the flame rod
- Temperature in excess of 600 °F (316 °C) at the flame electrode insulator causing short to ground.

(M) & (R) 3-Phase Rotation function (Model 176D only)

Inputs are made via the test lead terminals L1/L2/L3. Phase Rotation directions are indicated as symbolic movements by the LCD segments. Defaults at (M). Press **SELECT** button momentarily toggles between (M) and (R) modes.

(M): Hi-sensitivity mode, which detects relatively low signal outputs generated from motor spinning, for checking phase connections of Motors.

(R): Normal-sensitivity mode for identifying phase sequence of Electricity Supply.

CAUTION

Proper Rotation detection relies on solid signal connection to all three test lead terminals simultaneously. Any single disconnection will lead to detection failure and may produce false indication. To verify signal connection and hence proper meter indication, swap any two connects (to the meter) to check for meter indication of reverse movement

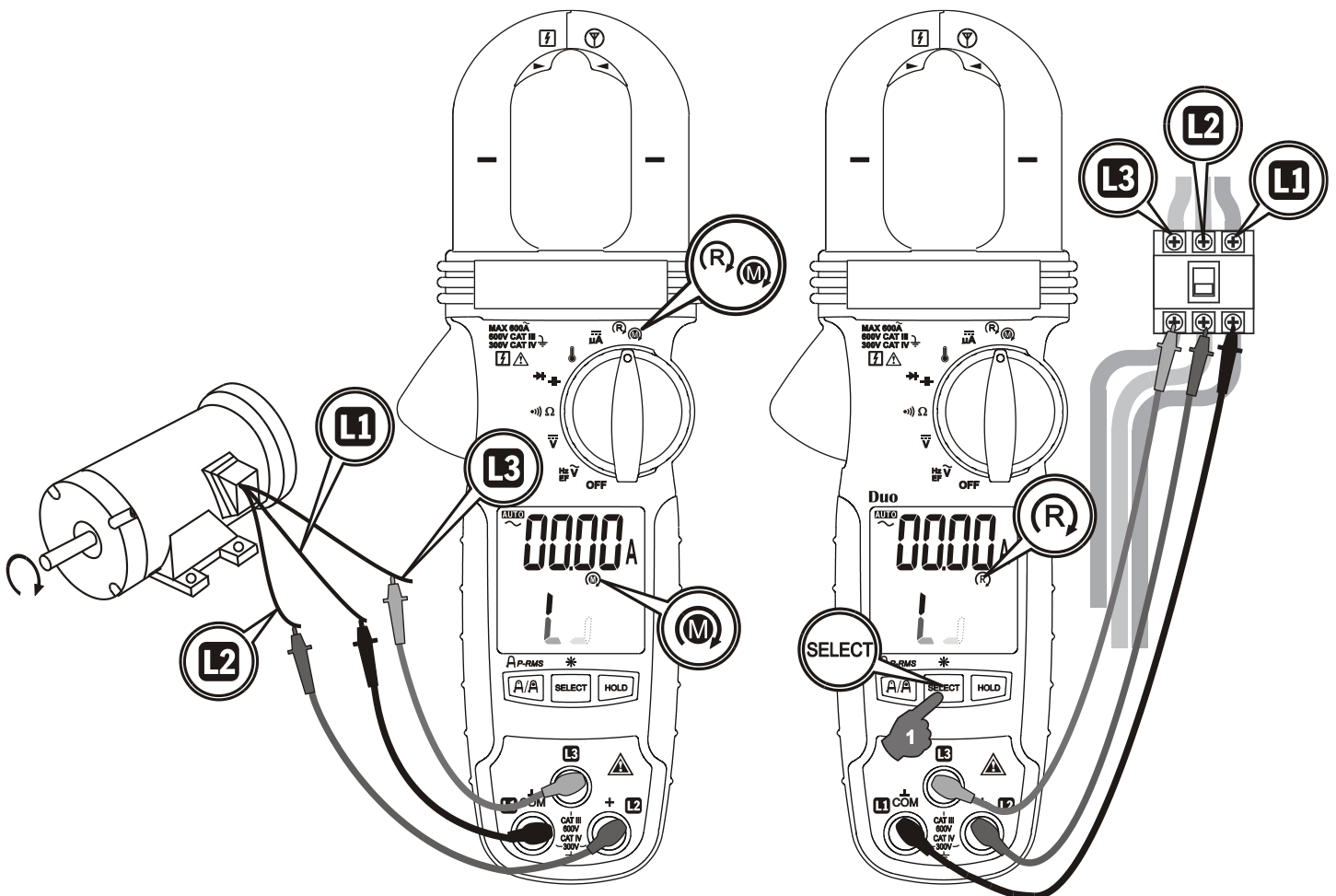

Using the Hi-sensitivity mode (M) for Motors:

Connect to the Motor as illustrated. Be sure the electricity supply is removed. From the perspective of looking down the shaft of the motor, speed-spin it clockwise to generate sufficient signal strength for proper meter detection. If the meter indicates a clockwise movement, the motor leads connected to L1, L2 and L3 of the meter are L1, L2 and L3 (also known as R, S and T) respectively. If the meter indicates a counter-clockwise movement, swap any two connects between the meter and motor. Then retest.

Using the Normal mode (R) for Electricity Supply:

Connect to the Electricity Supply as illustrated. If the meter indicates a clockwise movement, the phases connected to L1, L2 and L3 of the meter are L1, L2 and L3 (also known as R, S and T) respectively. If the meter indicates a counter-clockwise movement, swap any two connects between the meter and phases. Then retest. Connect the above mentioned L1, L2 and L3 of a Motor and that of the Electricity Supply respectively should be able to get a clockwise motor movement.

Using the Complementary Beeper feature:

The Complementary Beeper feature can be selected in Power-up option. Press and hold the A/A button while turning the meter on to enable. When the LCD segments indicate a clockwise movement, the beeper sounds a single long beep per segment cycle. When the segments indicate a counter clockwise movement, the beeper sounds 3 short beeps per segment cycle.

Hold feature

Hold feature freezes the display for later view. LCD "H" turns on. Press the **HOLD** button momentarily to toggle the hold feature.

80ms PEAK-RMS mode for Clamp-on ACA functions

Press **P-RMS** button for one second or more to toggle the **PEAK-RMS** mode. It captures RMS values of inrush current in duration as short as 80ms. LCD annunciator "**P-RMS**" turns on. Auto-Power-Off is disabled automatically in this mode.

LCD display Backlight

Press the **SELECT** button for 1 second or more to toggle the LCD backlight on/off. The backlight will also be turned off automatically after 20 minutes to extend battery life.

Intelligent Auto-Power-Off (APO)

The Auto-Power-off (APO) mode turns the meter off automatically to extend battery life after approximately 32 minutes of no specified activities, where applicable:

- 1) Rotary switch or push button operations
- 2) Significant measuring readings of above 8.5% of ranges
- 3) Non-OL readings for Resistance, Continuity or Diode function
- 4) Non-zero readings for Hz function
- 5) Significant movement indication as in Phase Rotation functions

In other words, the meter will intelligently avoid entering the APO mode when it is in normal measurements. To wake up the meter from APO, press the **SELECT** button momentarily and release, or turn the rotary switch OFF and then back on. Always turn the rotary switch to the OFF position when the meter is not in use

5) MAINTENANCE

WARNING

To avoid electrical shock, disconnect the meter from any circuit, remove the test leads from the input jacks and turn OFF the meter before opening the case or battery door. Do not operate with open case or battery door.

Trouble Shooting

If the instrument fails to operate, check batteries and test leads etc., and replace as necessary. Double check operating procedure as described in this user's manual.

If the instrument voltage-resistance input terminal has subjected to high voltage transient (caused by lightning or switching surge to the system under test) by accident or abnormal conditions of operation, the protective impedance components in series might be blown off (become high impedance) like open fuses to protect the user and the meter. Most measuring functions through this terminal might then be open circuit. Such components should only be replaced by qualified technician. Refer to the LIMITED WARRANTY section for obtaining warranty or repairing service.

Accuracy and Calibration

Accuracy is specified for a period of one year after calibration. Periodic calibration at intervals of one year is recommended to maintain meter accuracy. Refer to the LIMITED WARRANTY section for obtaining calibration, repairing or warranty service.

Cleaning and Storage

Periodically wipe the case with a damp cloth and mild detergent; do not use abrasives or solvents. If the meter is not to be used for periods of longer than 60 days, remove the batteries and store them separately.

Battery replacement

The meter uses standard 1.5V AAA Size (IEC R03) battery X 2

Loosen the 2 captive screws from the battery cover case. Lift the battery cover case. Replace the batteries. Replace battery cover case. Re-fasten the screws.

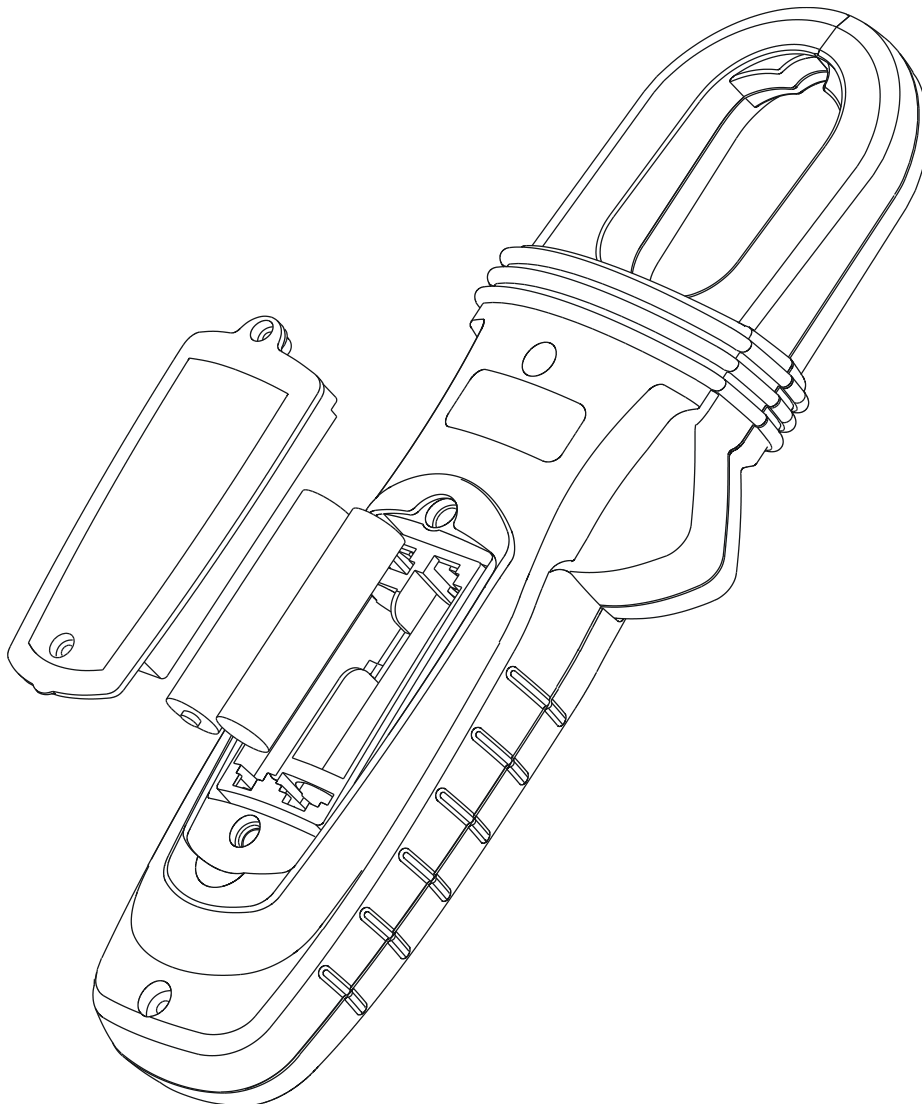

GENERAL SPECIFICATIONS

Display: 3-5/6 digits 6000 counts; dual display

Polarity: Automatic

Update Rate: 5 per second nominal

Operating Temperature: 0°C to 40°C

Relative Humidity: Maximum relative humidity 80% for temperature up to 31°C decreasing linearly to 50% relative humidity at 40°C

Pollution degree: 2

Storage Temperature: -20°C to 60°C, < 80% R.H. (with battery removed)

Altitude: Operating below 2000m

Temperature Coefficient: nominal $0.15 \times (\text{specified accuracy}) / ^\circ\text{C}$ @ (0°C -- 18°C or 28°C -- 40°C), or otherwise specified

Sensing: True RMS

Safety: Double insulation per UL/IEC/EN61010-1 Ed. 3.0, CAN/CSA C22.2 No. 61010-1 Ed. 3.0, UL/IEC/EN61010-2-032 Ed. 3.0, UL/IEC/EN61010-2-033 Ed. 1.0 to CAT III 600V and CAT IV 300V AC & DC

Transient Protection: 6.0kV (1.2/50 μ s surge)

Overload Protections:

Clamp-on jaws: 600A rms continuous

“ + ” & COM Terminals (all other functions): 600VDC/VAC rms

E.M.C.: Meets EN61326-1:2013

Temperature function at 80MHz ~ 150MHz:

In an RF field of 1V/m:

Total Accuracy = Specified Accuracy + 25 digits

Other functions:

In an RF field of 3V/m:

Total Accuracy = Specified Accuracy + 20 digits

Power Supply: 1.5V AAA Size battery X 2

Power Consumption: 6.2mA typical

Low Battery Indication:

Below approx. 2.85V for Capacitance & Hz

Below approx. 2.5V for other functions

APO Timing: Idle for 32 minutes approx.

APO Consumption: 5 μ A typical

Dimension (LxWxH): 217 x 76 x 37mm

Weight: 186gm

Jaw opening & Conductor diameter : 30mm max

Accessories: Test lead set, User's manual, Soft carrying pouch, Bkp60 banana plug K-type thermocouple (Models 175D & 176D only), Alligator Clip set (Model 176D only)

Optional Purchase Accessories: BKB32 banana plug to type-K socket plug adaptor (Models 175D & 176D only)

Special Features: AmpTip™ low-current range; Display Hold; EF-Detection (NCV); Backlighted LCD; 80ms Peak-RMS mode for inrush current; 3-Phase Rotation detection (Models 176D only)

Electrical Specifications

Accuracy is \pm (% reading digits + number of digits) or otherwise specified, at $23^{\circ}\text{C} \pm 5^{\circ}\text{C}$.

Maximum Crest Factor < 2.5 : 1 at full scale & < 5 : 1 at half scale or otherwise specified, and with frequency components within the specified frequency bandwidth for non-sinusoidal waveforms.

DC Voltage

RANGE	Accuracy
600.0V	1.0% + 5d

Input Impedance: $10\text{M}\Omega$, 100 pF nominal

AC Voltage (with Digital Low Pass Filter)

RANGE	Accuracy
50Hz ~ 60Hz	
600.0V	1.0% + 5d

Input Impedance: $10\text{M}\Omega$, 100 pF nominal

Ohm

RANGE	Accuracy
600.0 Ω , 6.000K Ω , 60.00K Ω	1.0% + 5d
600.0K Ω ¹⁾ , 6000K Ω ²⁾	1.2% + 5d

Open Circuit Voltage: 1.7VDC typical

¹⁾Test Current: 2 μA typical

²⁾Test Current: 0.2 μA typical

Audible Continuity Tester

Audible Threshold: Between 10Ω and 250Ω

Response time: 32ms approx.

Capacitance

RANGE	Accuracy ¹⁾
200.0 μ F, 2500 μ F	2.0% + 4d

¹⁾Accuracies with film capacitor or better

Diode Tester

RANGE	Accuracy
3.000V	1.5% + 5d

Test Current: 0.3mA typical

Open Circuit Voltage: < 3.5VDC typical

DC μ A (Models 175D & 176D only)

RANGE	Accuracy	Burden Voltage
200.0 μ A, 2000 μ A	1.0% + 5d	3.5mV/ μ A

Temperature (Models 175D & 176D only)

RANGE	Accuracy ^{1) 2)}
-40.0 °C ~ 99.9 °C	1.0% + 0.8°C
100 °C ~ 400 °C	1.0% + 1°C
-40.0 °F ~ 99.9 °F	1.0% + 1.5°F
100 °F ~ 752 °F	1.0% + 2°F

¹⁾K-type thermocouple range & accuracy not included

²⁾Accuracies assume meter interior has the same temperature of the ambient (isothermal stage) for a correct junction voltage compensation. Allow enough time to reach the isothermal stage for a significant change of ambient temperature. It can take up to an hour for changes > 5°C.

AmpTip™ Clamp-on ACA

RANGE	Accuracy ^{1) 2) 3) 4)}
50Hz ~ 60Hz	
60.00A	1.5% + 5d

¹⁾Induced error from adjacent current-carrying conductor: <0.06A/A

²⁾Induced error from ACV measurement < 0.60A /kV @50/60Hz

³⁾Add 10d to the specified accuracy @ < 6A

⁴⁾Induced non-zero residual while beeper turns on: < 20d

Regular Clamp-on ACA

RANGE	Accuracy ^{1) 2) 3) 4)}
50Hz ~ 100Hz	
60.00A ⁵⁾ , 600.0A	1.8% + 5d
100Hz ~ 400Hz	
60.00A ⁵⁾ , 600.0A	2.0% + 5d

¹⁾Induced error from adjacent current-carrying conductor: <0.06A/A

²⁾ Induced error from ACV measurement < 0.60A /kV @50/60Hz

³⁾Specified accuracy is for measurements made at the jaw center. When the conductor is not positioned at the jaw center, add 2% to specified accuracy for position errors

⁴⁾Induced non-zero residual while beeper turns on: < 20d

⁵⁾Add 10d to specified accuracy @ < 6A

80ms PEAK-RMS for Clamp-on ACA functions

Response: 80ms to > 90% of specifications, and is specified from 2% of range.

Hz Line Level Frequency

Function	Sensitivity (Sine RMS) ¹⁾	Range
600V	50V	5.00Hz ~ 999.9Hz

Accuracy: 1%+5d

¹⁾DC-bias, if any, not more than 50% of Sine RMS

Non-Contact EF-Detection

Bar-Graph Indication	EF-H (High Sensitivity)	EF-L (Low Sensitivity)
	Typical Voltage (Tolerance)	
-	10V (5V ~ 25V)	40V (32V ~ 70V)
--	25V (20V ~ 66V)	110V (55V ~ 165V)
---	55V (50V ~ 125V)	220V (130V ~ 265V)
----	110V (90V ~200V)	400V (250V ~ 500V)
-----	220V (>180V)	550V (>430V)

Indication: Bar-graph segments & audible beep tones proportional to the field strength

Detection Frequency: 50/60Hz

Detection Antenna: Top side of the stationary jaw

Probe-Contact EF-Detection: For more precise indication of live wires, such as distinguishing between live and ground connections, use direct contact testing with one single test-probe via an input terminal. The COM terminal (Black) has the best sensitivity.

- NOTE -

- NOTE -

LIMITED WARRANTY

BRYMEN warrants to the original product purchaser that each product it manufactures will be free from defects in material and workmanship under normal use and service within a period of one year from the date of purchase. BRYMEN's warranty does not apply to accessories, fuses, fusible resistors, spark gaps, varistors, batteries or any product which, in BRYMEN's opinion, has been misused, altered, neglected, or damaged by accident or abnormal conditions of operation or handling.

To obtain warranty service, contact your nearest BRYMEN authorized agent or send the product, with proof of purchase and description of the difficulty, postage and insurance prepaid, to BRYMEN TECHNOLOGY CORPORATION. BRYMEN assumes no risk for damage in transit. BRYMEN will, at its option, repair or replace the defective product free of charge. However, if BRYMEN determines that the failure was caused by misused, altered, neglected, or damaged by accident or abnormal conditions of operation or handling, you will be billed for the repair.

THIS WARRANTY IS EXCLUSIVE AND IS IN LIEU OF ALL OTHER WARRANTIES, EXPRESSED OR IMPLIED, INCLUDING BUT NOT LIMITED TO ANY IMPLIED WARRANTY OR MERCHANTABILITY OR FITNESS FOR A PARTICULAR PURPOSE OR USE. BRYMEN WILL NOT BE LIABLE FOR ANY SPECIAL, INDIRECT, INCIDENTAL OR CONSEQUENTIAL DAMAGES.



BRYMEN TECHNOLOGY CORPORATION

TEL:+886 2 2226 3396

FAX:+886 2 2225 0025

<http://www.brymen.com>



PRINTED ON RECYCLABLE PAPER, PLEASE RECYCLE

COPYRIGHT © MMXV Btc,

ALL RIGHTS RESERVED

P/N: 7M1C-1471-0000

PRINTED IN TAIWAN